

**NOTE:**

All construction shall confirm the following building codes.

1. **IBC 2018**  
**IFC 2018**
2. contractor shall coordinate his work and schedule to allow uninterrupted progress of all work and to complete within the established schedule.
3. schedule and coordinate work, verify delivery dates for any log dead items and materials to ensure their installation in the proper sequence of the job.
4. all dimension area to center line of wall, unless noted otherwise.  
all dimensions to be verified in field. any discrepancies to be brought to designer's attention without delay, written dimension take precedence over scaled dimensions.
5. contractors shall up areas affected by daily work and remove debris and material from site upon completion of work and dispose of off site in a lawful manner.  
contractor to maintain a cleaned and orderly work area at all times.
6. do not use paints, primers, sealers, or clues that emit flammable, toxic or noxious fumes, each trade shall be responsible to verify the material he is using and comply with manufacturers' written guarantee instruction for their use.
7. the general contractor shall be responsible to review the contraction documents for any discrepancies or omissions and resolve any conflicts with the designer & draftsman prior beginning construction.

# CITY OF NOGALES

## NAB KARAM PARK

### RESTROOM



**APPROVED**



Hector Tapia, AICP  
Community Development Director

*Hector Tapia*

PARCEL#: 101-50-020  
ZONE: GENERAL COMMERCIAL

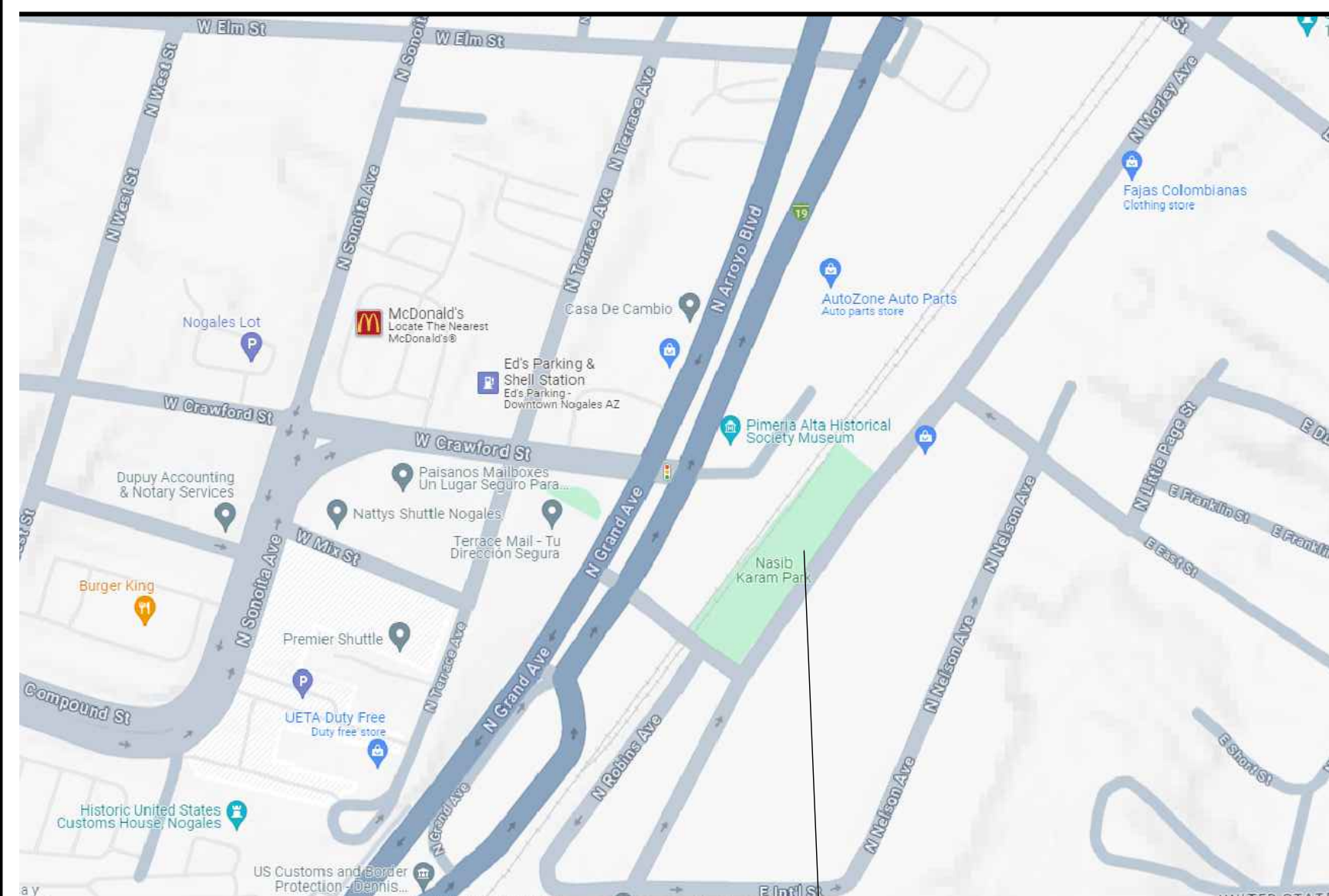

159 N. MORLEY AVE  
NOGALES, AZ.  
NAIB KARAM PARK

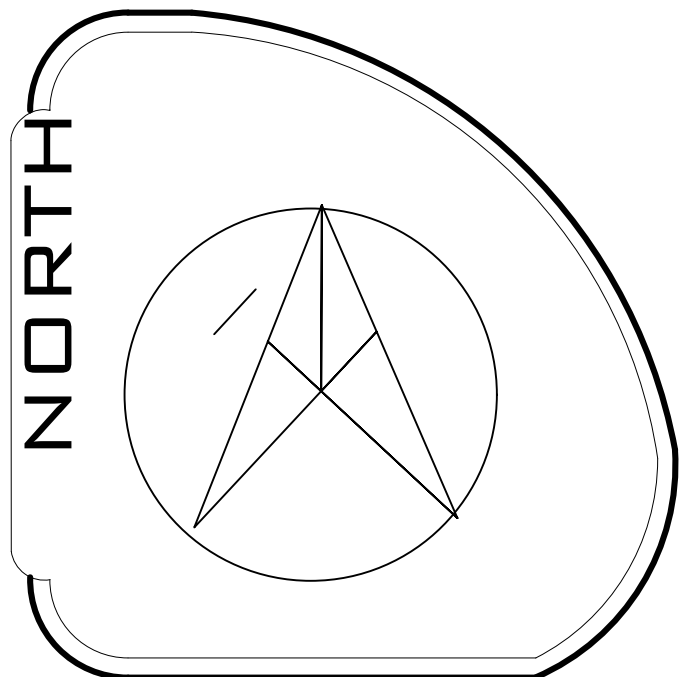

SPECIFICATIONS

INFO

DEPARTMENT  
**PLANNING AND ZONING**

COMMUNITY DEVELOPMENT

JOSEPH MIRANDA

DATE: 09/11/2024

SECTION:

DIRECTOR: HECTOR TAPIA

PROJECT

NAME  
NOGALES DOWNTOWN

ADDRESS:  
159 N. MORLEY AVE  
NOGALES, AZ, USA.

PLAN  
PLAN

SCALE: 1/2" = 1' DIMENSIONS FEET

CODE PLAN  
**A-01**

LOGO

# CITY OF NOGALES

## NAB KARAM PARK

### RESTROOM REMODEL

### DEMOLETION

**APPROVED**



Hector Tapia, AICP  
Community Development Director

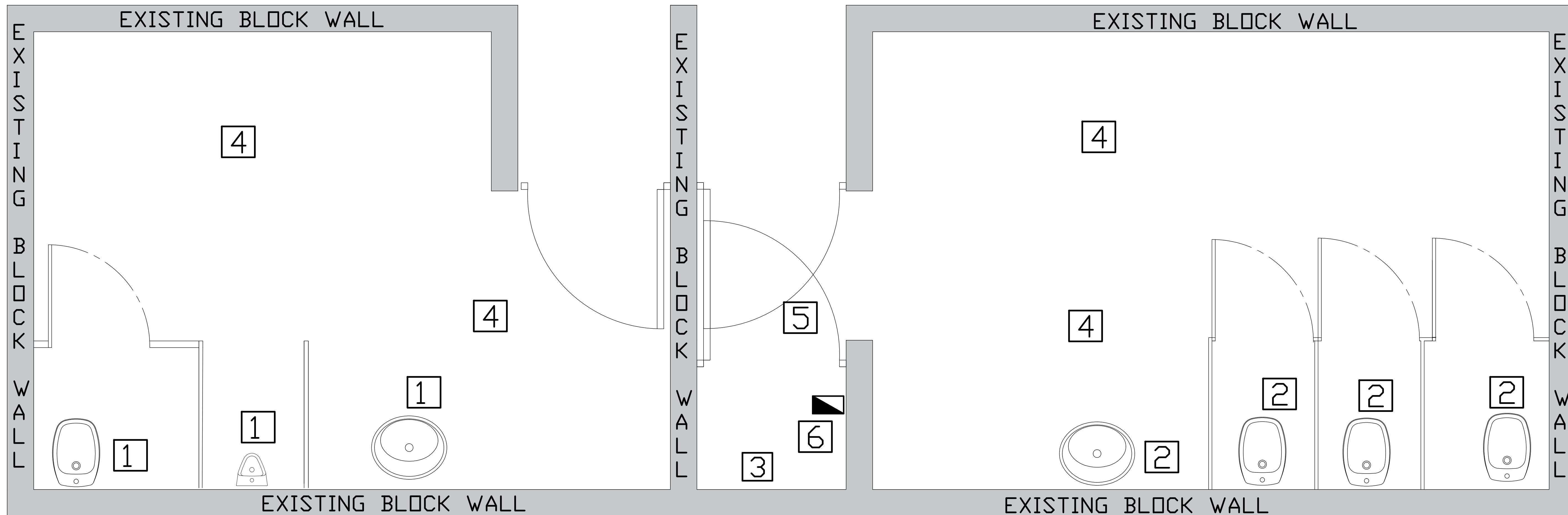

# EXISTING FLOOR PLAN

EXISTING BUILDING	
BATHROOM MEN	166.00SqFT
BATHROOM WOMEN	228.62SqFT

**NOTE: CITY STAFF TO DO ITEMS 1-6**

- ❑ REMOVE EXISTING MEN TOILETS, URINALS, AND SINKS.
- ❑ REMOVE EXISTING WOMEN TOILETS AND SINK.
- ❑ REMOVE WATER HEATER, MAINTENANCE DOOR, AND WALL WEST SIDE OF ROOM.
- ❑ REMOVE FLOOR AND WALL TILES.
- ❑ REMOVE ELECTRICAL PANEL, WIRES WILL BE REDIRECTED TO NEW MAINTENANCE ROOM (SEE NEW FLOOR PLAN).
- ❑ EXISTING BREAKER PANEL LOCATION.

❑ OLD PLUMBING LINES TO BE ABANDONED FILLED WITH CONCRETE SLURRY NEW LINES TO BE TRENCHED & PIPED WITH PROPER SLOPES

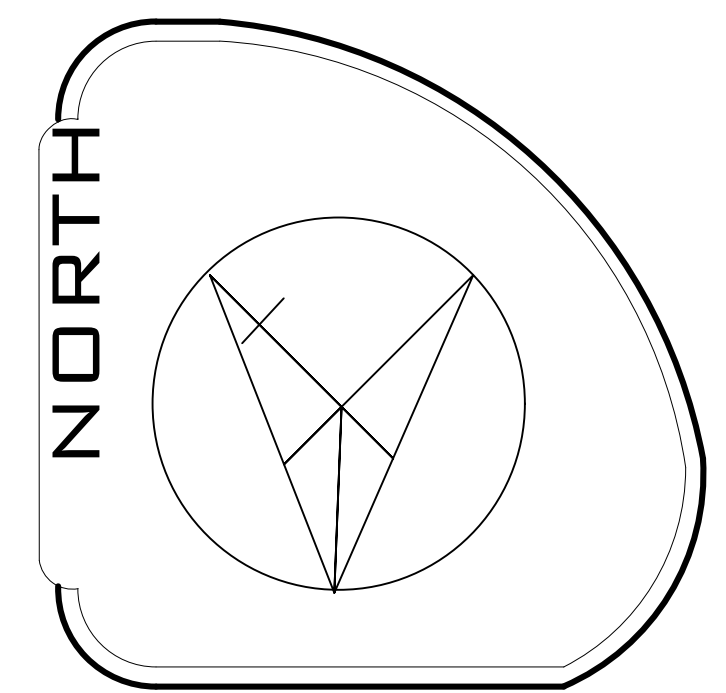

**DEPARTMENT**  
PLANNING AND ZONING  
COMMUNITY DEVELOPMENT

**INFO**

JOSEPH MIRANDA

DATE  
09/11/2024

DIRECTOR  
HECTOR TAPIA

**PROJECT**

NAME  
NOGALES DOWNTOWN

ADDRESS:  
159 N. MORLEY AVE  
NOGALES, AZ, USA.

PLAN  
EXISTING FLOOR PLAN

SCALE  
3/4"

**CODE PLAN**  
A- 02

**LOGO**

# CITY OF NOGALES NAB KARAM PARK RESTROOM REMODEL

APPROVED



Hector Tapia, AICP  
Community Development Director

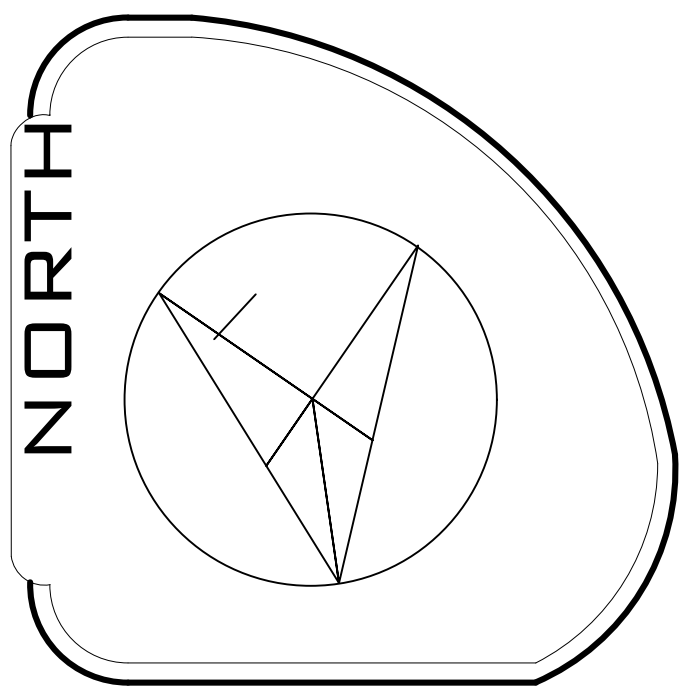

WOOD FRAME WALL  
EXTENSION

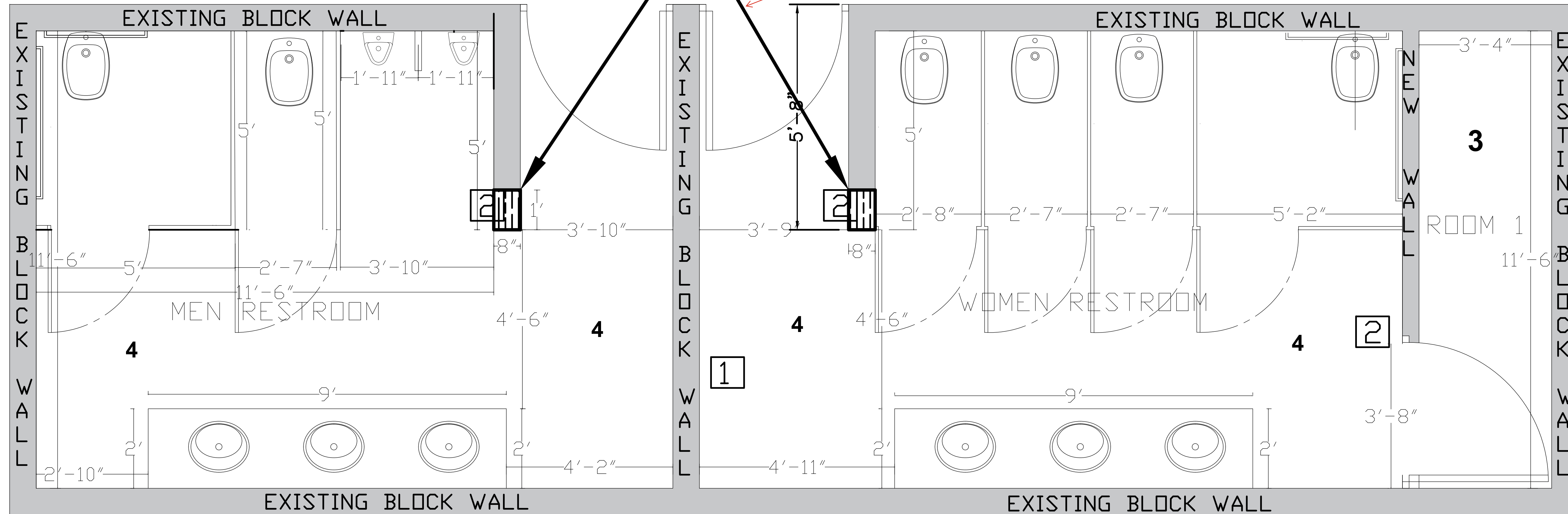

# PROPOSED FLOOR PLAN

## NOTES

- 1 EXISTING INTERIOR WALL TO REMAIN
- 2 NEW WALL- SEE DETAIL IN 1
- 3 - INSTALL A NEW TANK LESS WATER HEATER AT MAINTENANCE ROOM - SEE SHEET A-04
- 4 - CONCRETE FLOOR WITH INDUSTRIAL FINISH, COLOR TO BE SELECTED

## SPECIFICATION

DEPARTMENT  
**PLANNING AND ZONING**  
COMMUNITY DEVELOPMENT  
JOSEPH MIRANDA  
DATE  
09/11/2024  
DIRECTOR  
HECTOR TAPIA

NAME  
NOGALES DOWNTOWN  
ADDRESS  
159 N. MORLEY AVE  
NOGALES, AZ, USA.  
PLAN  
PROPOSED FLOOR PLAN

SCALE  
3/4"

CODE  
PLAN  
A- 03

LOGO





# CITY OF NOGALES NAB KARAM PARK RESTROOM

**APPROVED**



Hector Tapia, AICP  
Community Development Director

*Hector Tapia*

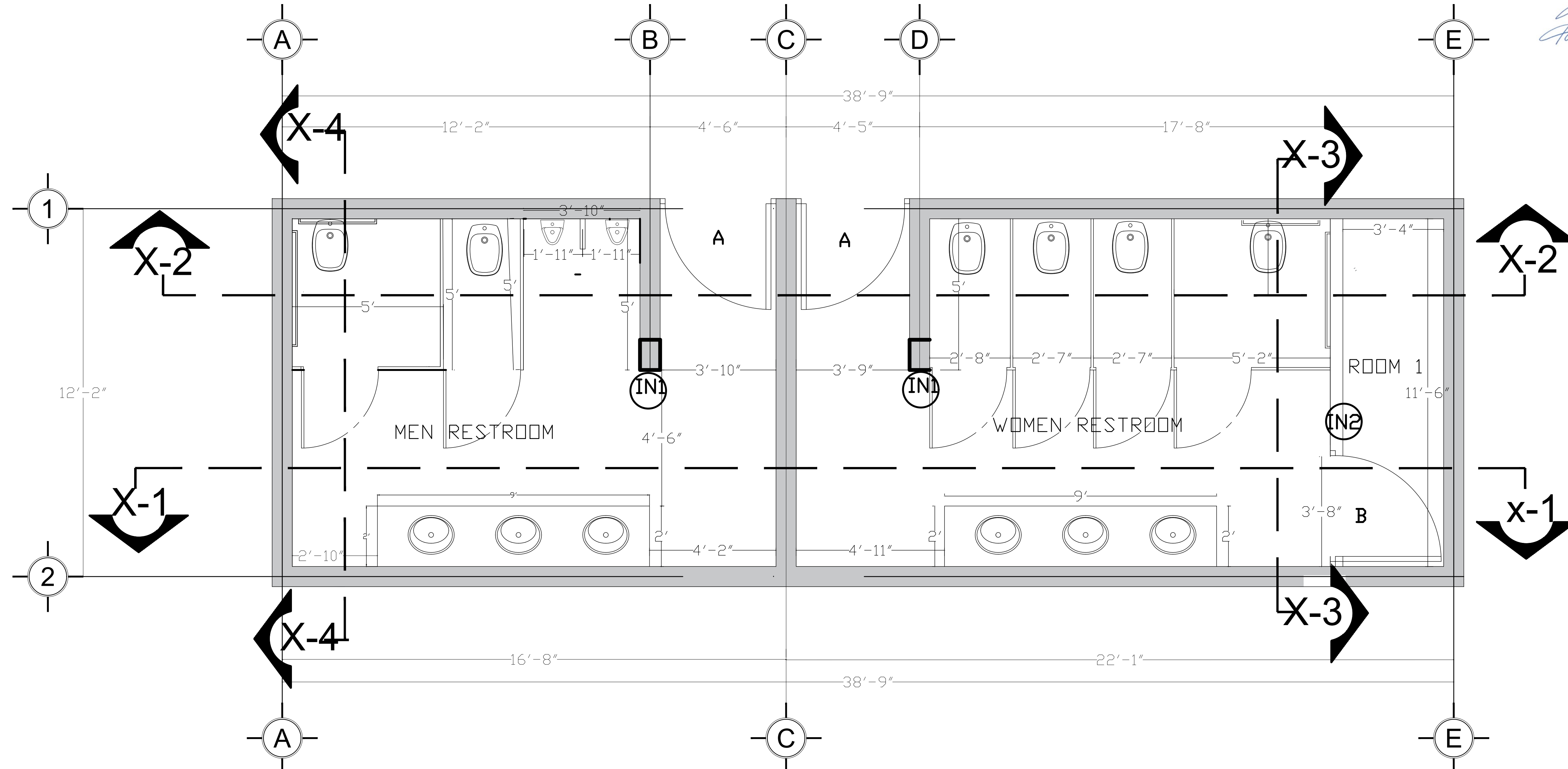
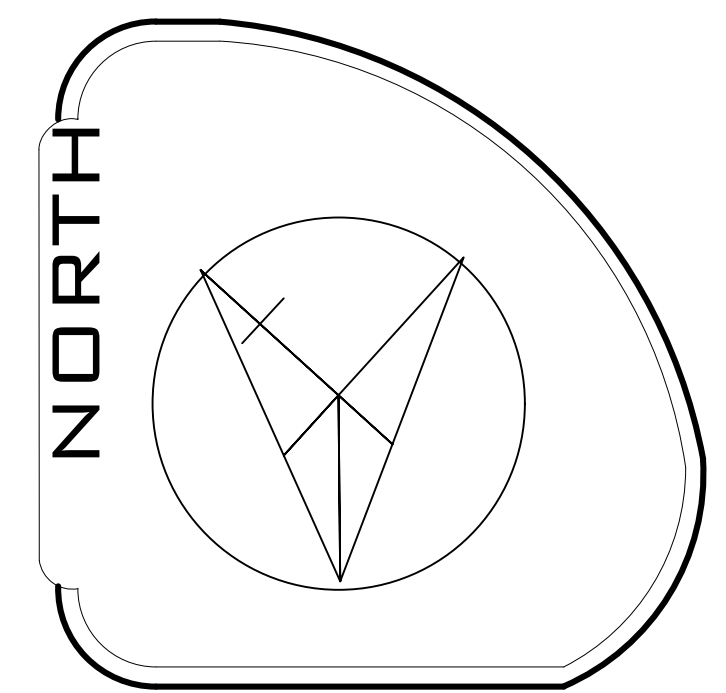

**SPECIFICATION**

**INFO**

DEPARTMENT  
**PLANNING AND ZONING**  
COMMUNITY DEVELOPMENT

JOSEPH MIRANDA

DATE:  
09/11/2024

DIRECTOR  
HECTOR TAPIA

**PROJECT**

NAME  
NOGALES DOWNTOWN

ADDRESS  
159 N. MORLEY AVE  
NOGALES, AZ, USA.

PLAN  
PROPOSED PLAN AND DOORS

SCALE  
1/2"

## BUILDING CROSS SECTION VIEWS

DOORS SCHEDULE					
CODE	WIDTH	HEIGHT	TYPE	QTY.	REMARKS
A	36	80	METAL	2	Fire-Rated, Right-Hand
B	36	80	METAL	1	Right- hand

**CODE PLAN**

**LOGO**

**A- 05**

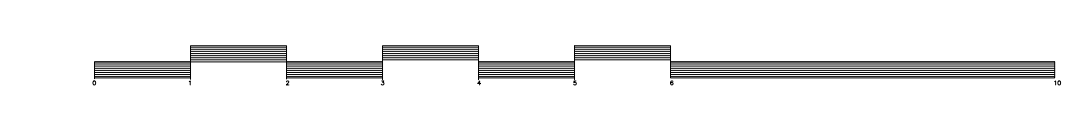

# CITY OF NOGALES NAB KARAM PARK RESTROOM

**APPROVED**



Hector Tapia, AICP  
Community Development Director

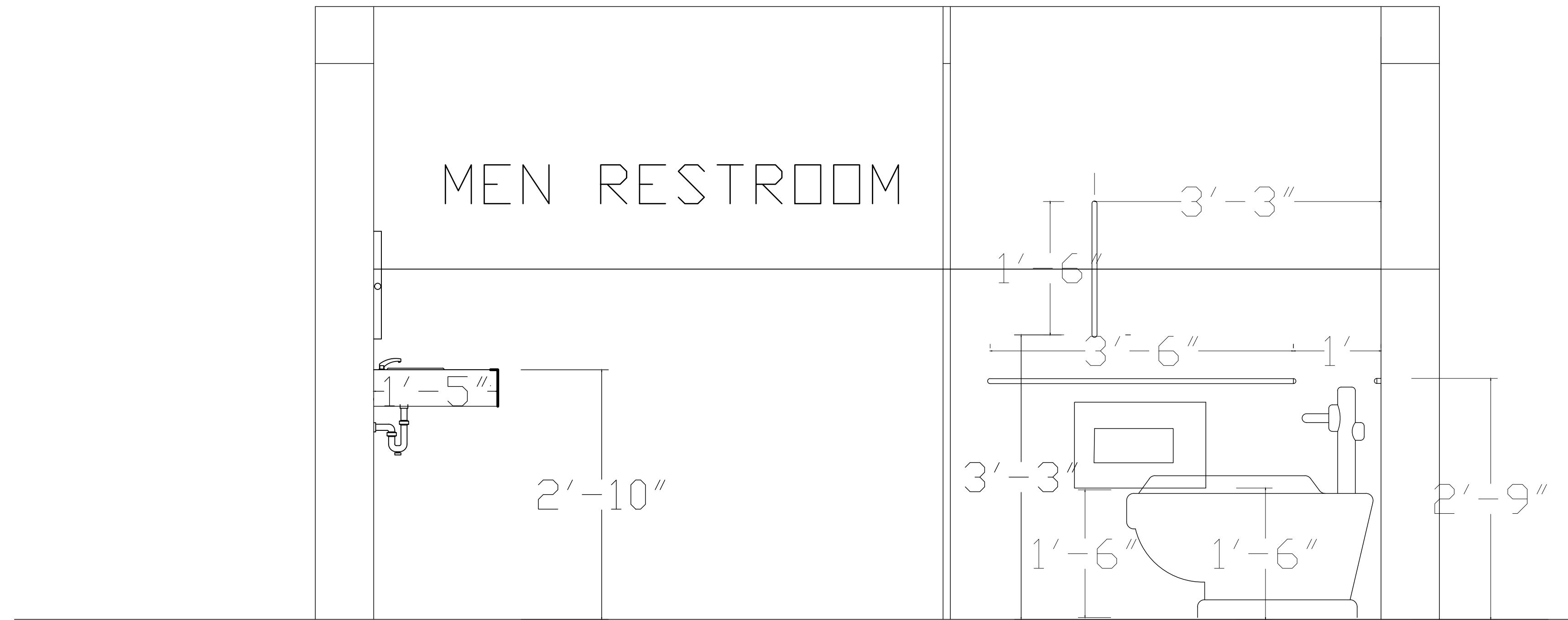
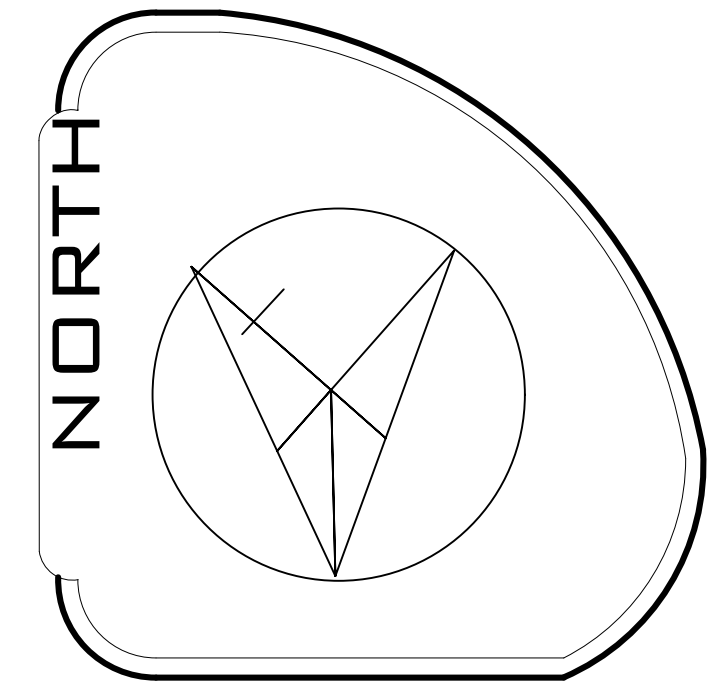

## INTERIOR X-4

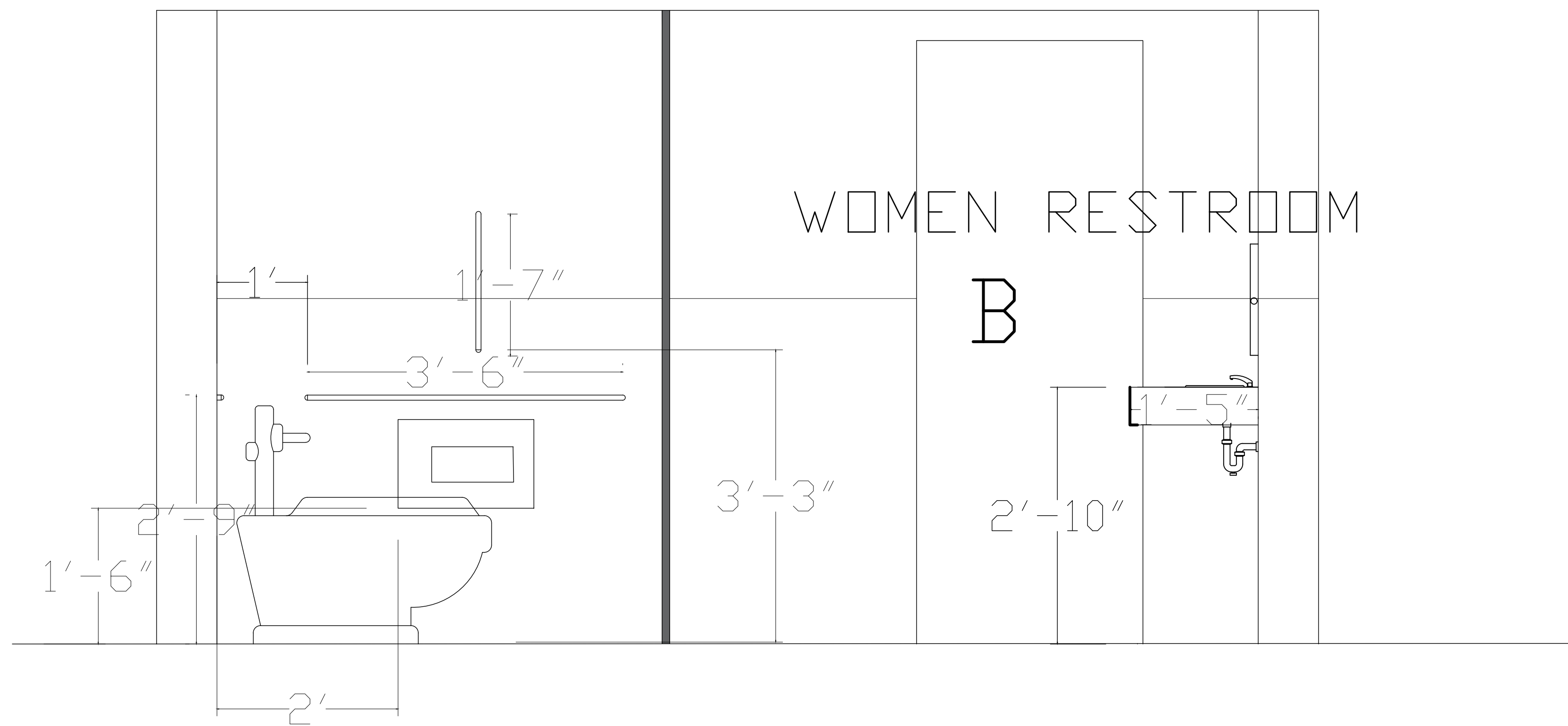
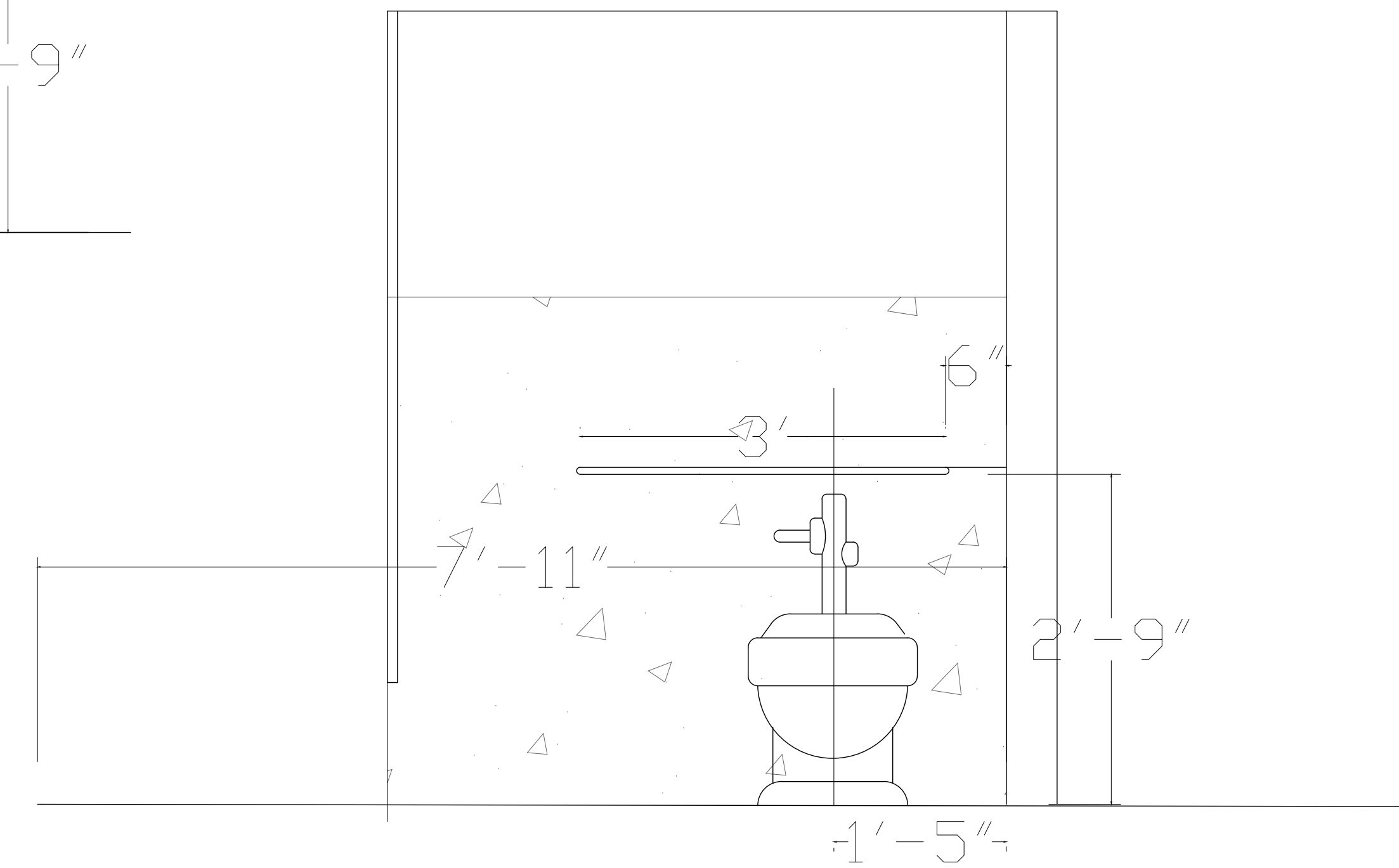

## INTERIOR X-3

**NOTE: (Proposed tile to meet this requirement)**  
WALL SHALL BE INSTALLED WITH A SMOOTH, HARD, NON-ABSORBENT SURFACE TO A HEIGHT NOT LESS THAN 4 FEET ON AREAS THAT ARE WITHIN 2 FEET FROM SINKS OR TOILETS WITH A BASE THAT EXTENDS UPWARDS NO LESS THAN 4"

SPECIFICATIONS

INFO

DEPARTMENT  
**PLANNING AND ZONING**  
COMMUNITY DEVELOPMENT

JOSEPH MIRANDA

DATE:  
09/11/2024

DIRECTOR

HECTOR TAPIA

PROJECT

NAME  
NOGALES DOWNTOWN

ADDRESS  
159 N. MORLEY AVE  
NOGALES, AZ, USA.

PLAN  
CROSS SECTIONAL PLAN

SCALE  
1" = 1'-0"

DIMENSIONS  
FEET

CODE  
PLAN

A-05.1

LOGO

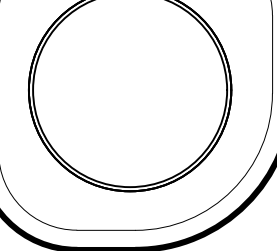

# CITY OF NOGALES NAB KARAM PARK RESTROOM

APPROVED



Hector Tapia, AICP  
Community Development Director

*Hector Tapia*

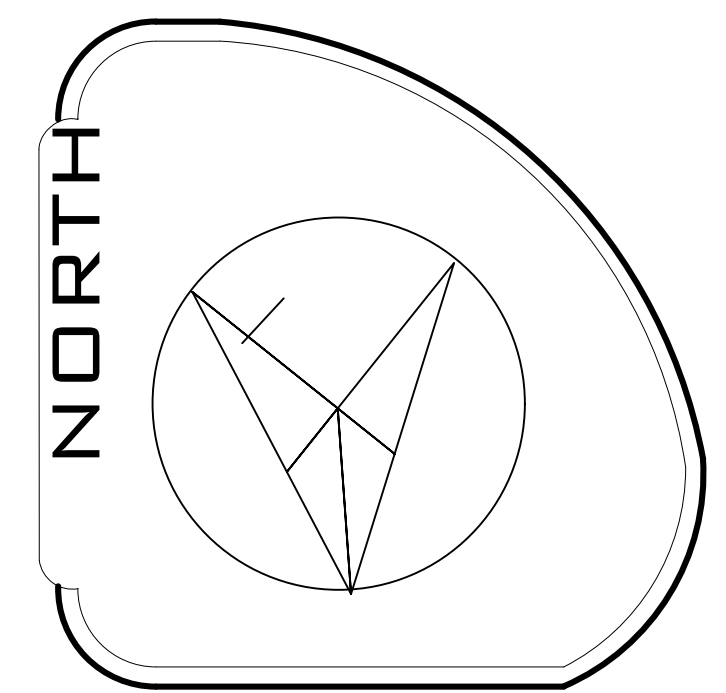

## WALL EXTENSION DETAIL

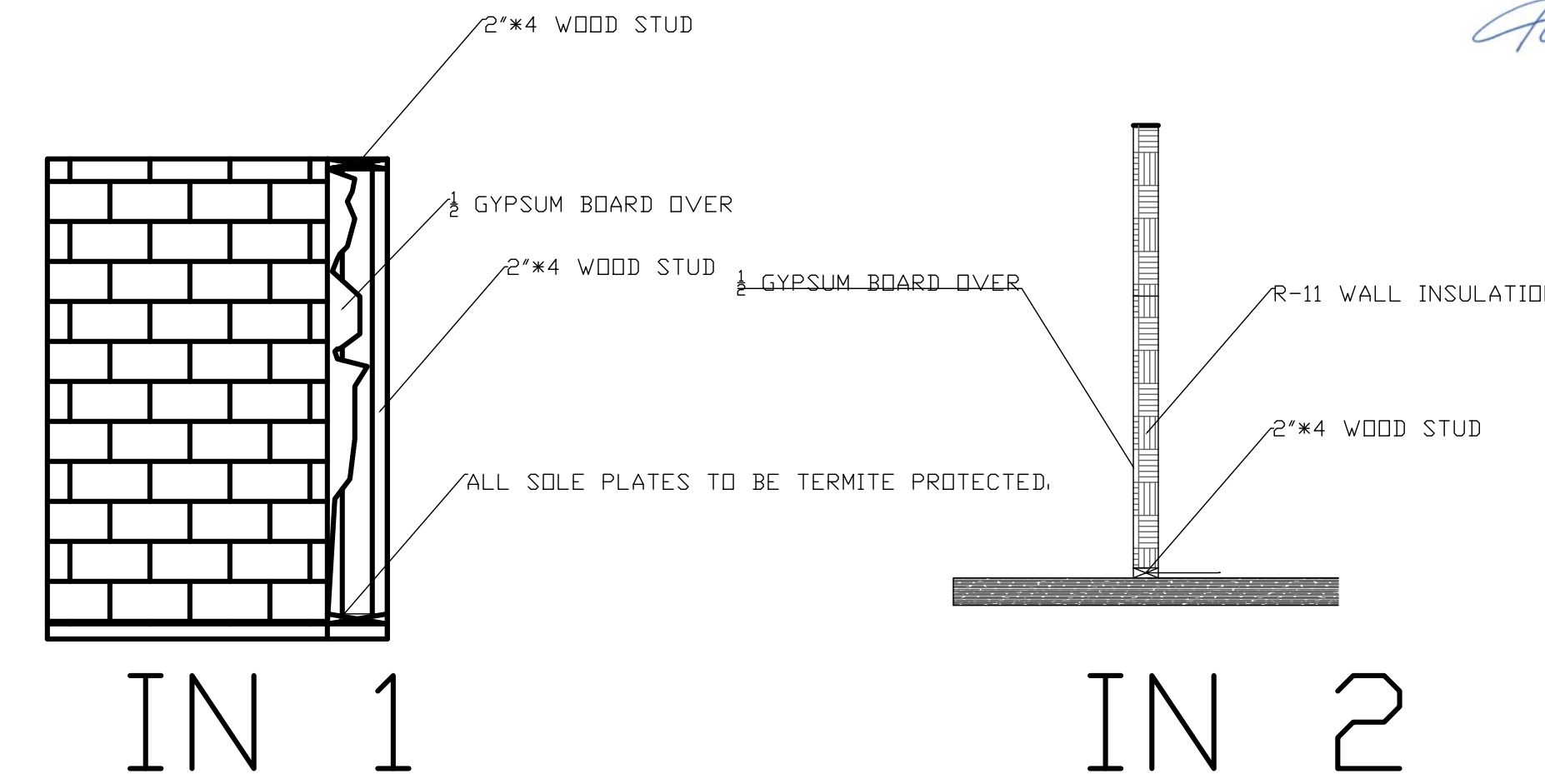

#PPU24-10 Downtown Gray Interior Paint  
and Primer in One (Typ.) - all walls above tile finish line

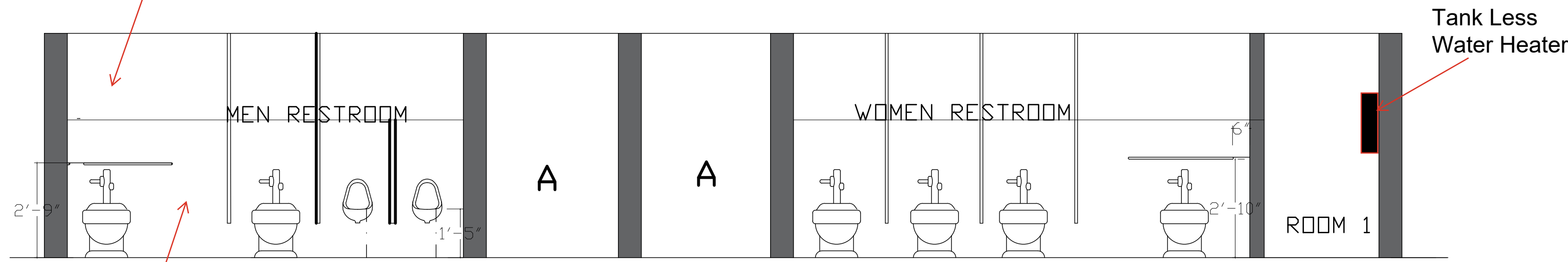

## INTERIOR X-2

Wall Tile: MSI Yordan Graphite 24 in. x 48 in. Matte Porcelain Stone  
Look (SKU #: 1007124483) Typ., 48" high on all walls.

Stucco Finish  
Downtown Gray  
PPU24-10 Exterior Enamel Paint

Concrete Floor  
Hard Film Floor Finish

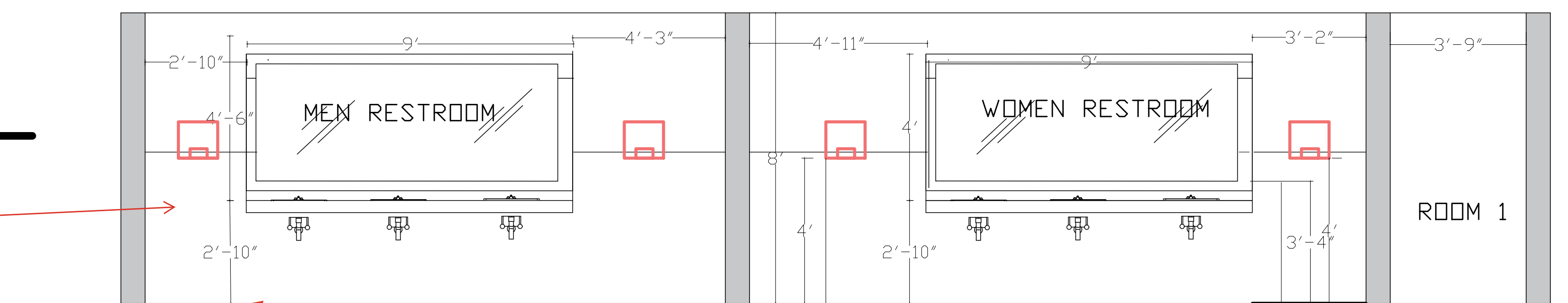

## INTERIOR X-1

## FRONT BUILDING ELEVATION

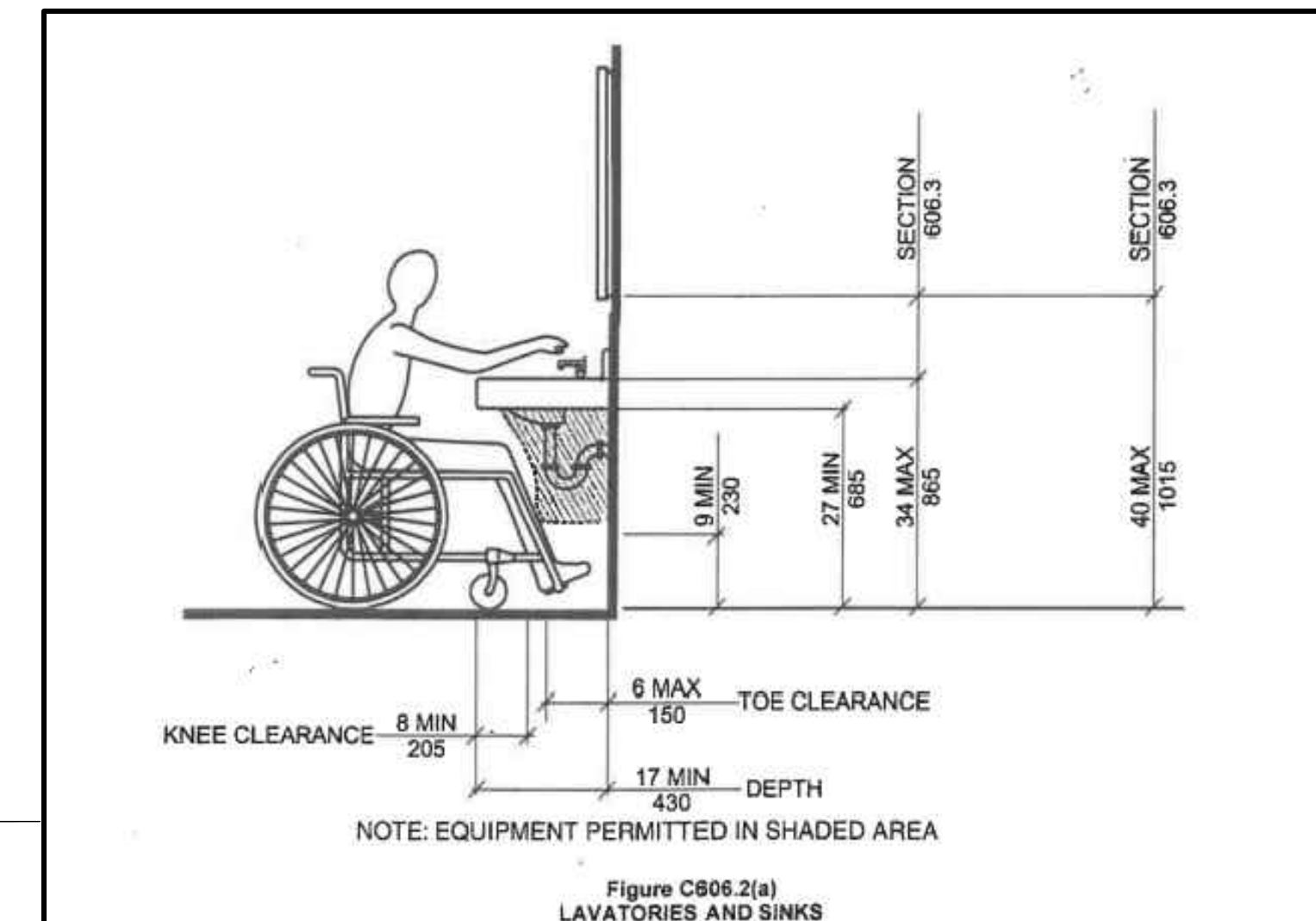
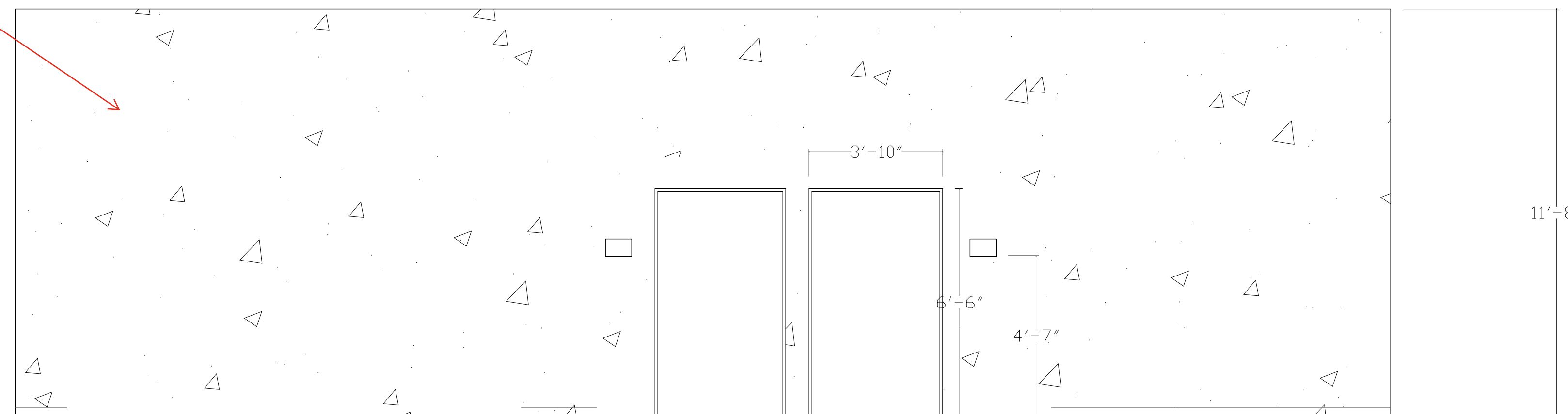

SPECIFICATIONS

DEPARTMENT  
PLANNING AND  
ZONING  
COMMUNITY  
DEVELOPMENT  
JOSEPH MIRANDA

DATE:  
09/11/2024  
DIRECTOR  
HECTOR TAPIA

NAME  
NOGALES DOWNTOWN  
ADDRESS  
159 N. MORLEY AVE  
NOGALES, AZ, USA.

PLAN  
CROSS SECTION PLAN

SCALE  
1/8" = 1'-0"  
DIMENSIONS  
FEET

CODE  
PLAN  
A-05.2

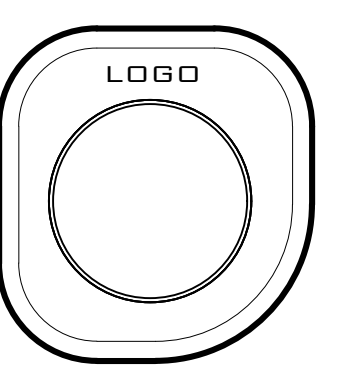

# CITY OF NOGALES NAB KARAM PARK RESTROOM

PLUMBING SCHEDULE							
MARK	FIXTURE	HW	CM	WASTE	VENT	QTY	FEACH TOTAL
P-1	LAVATORY	1/2"	1/2"	2'	1 1/2'	6	2 12
P-2	WATER CLOSET FLUSH VALVE TYPE	1/2"	1/2"	3'	2'	6	6 36
P-3	URINAL	1/2"	1/2"	2'	1 1/2'	2	2 4

APPROVED



Hector Tapia, AICP  
Community Development Director

*Hector Tapia*

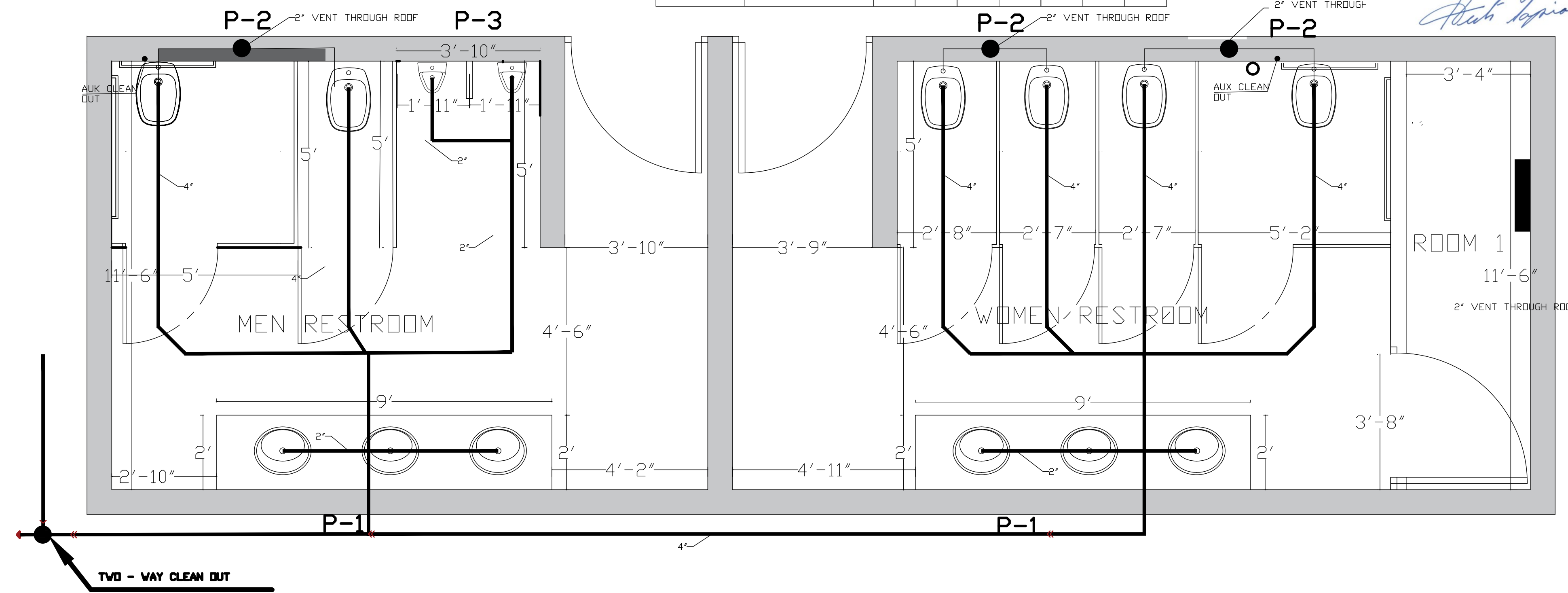
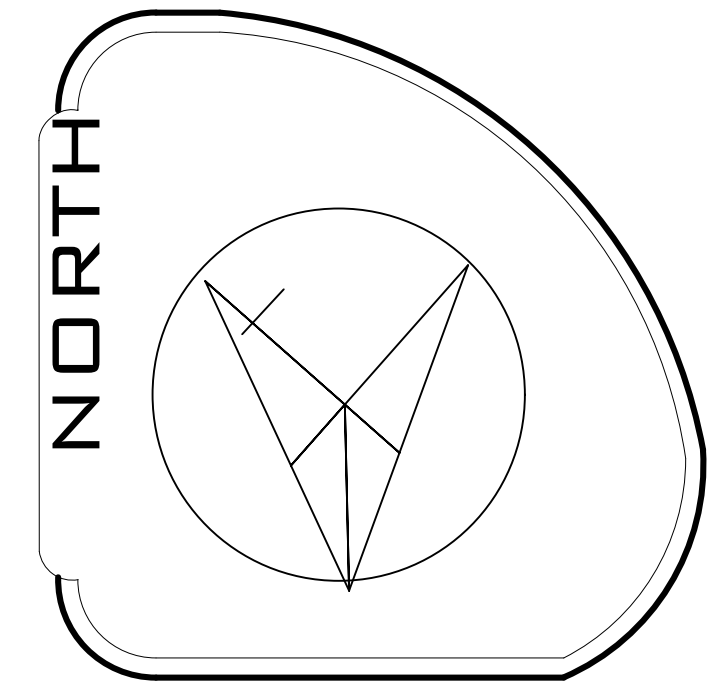

## SEWER LINES

PLUMBING LEGEND	
COLD WATER	=====
HOT WATER	=====
SANITARY LINE INDICATED ON PLANE	=====

NOTE:  
1 CONTRACTOR TO INSTALL  
 FURRING WALL (2\*2)  
 TO RUN THE WATER LINES.

EcoSmart 7.0 GPM Self-Modulating 240V 36 kW Bottom Connect Electric Residential Tankless Water Heater 150 Amps

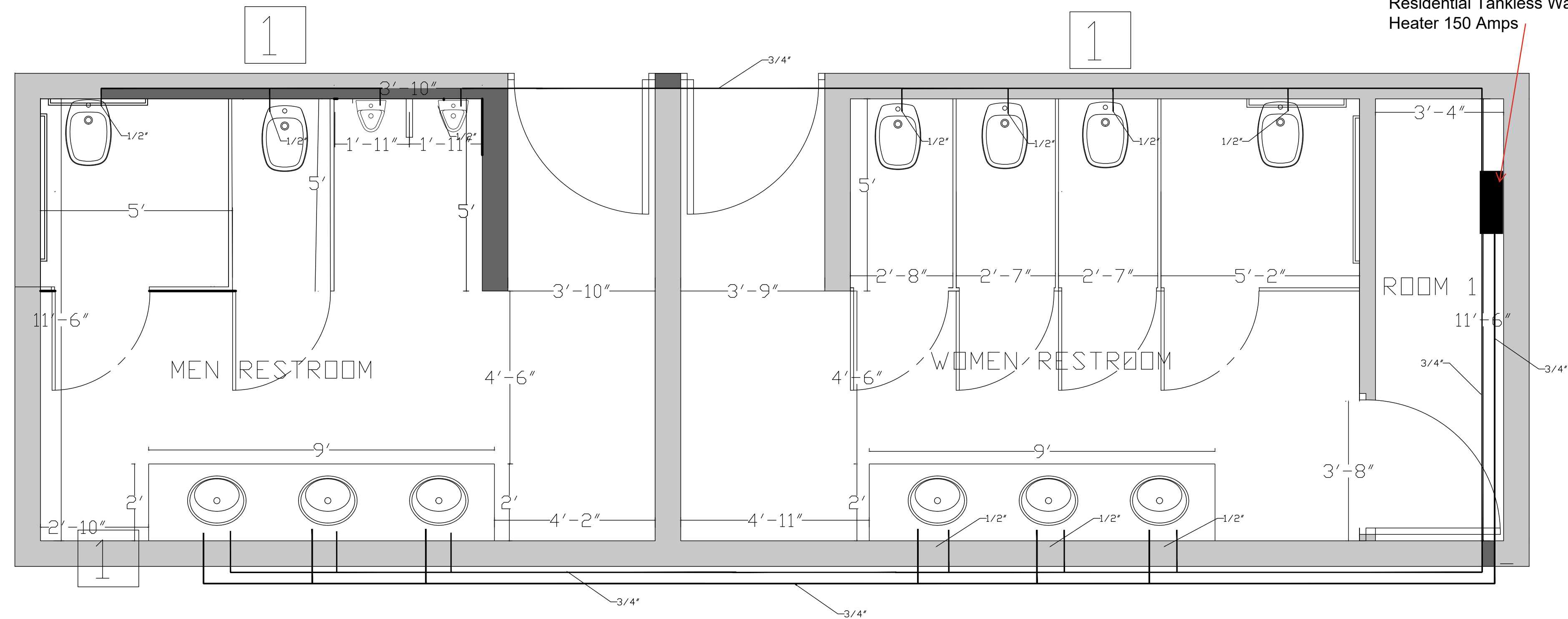

## WATER LINES

SPECIFICATIONS

INFO

DEPARTMENT  
**PLANNING AND ZONING**  
 COMMUNITY DEVELOPMENT  
 JOSEPH MIRANDA

DATE:  
 09/11/2024  
 DIRECTOR  
 HECTOR TAPIA

PROJECT

NAME  
 NOGALES DOWNTOWN  
 ADDRESS  
 159 N. MORLEY AVE  
 NOGALES, AZ, USA.  
 PLAN  
 PLUMBING PLAN

SCALE  
 1/2"

CODE PLAN  
 A- 06

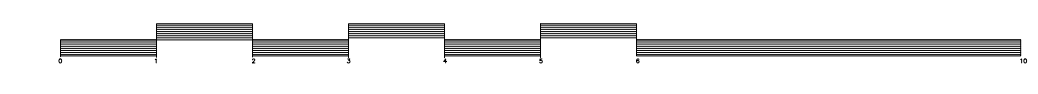



# ADA RAMP CITY OF NOGALES NAB KARAM PARK

P-1

## RESTROOM

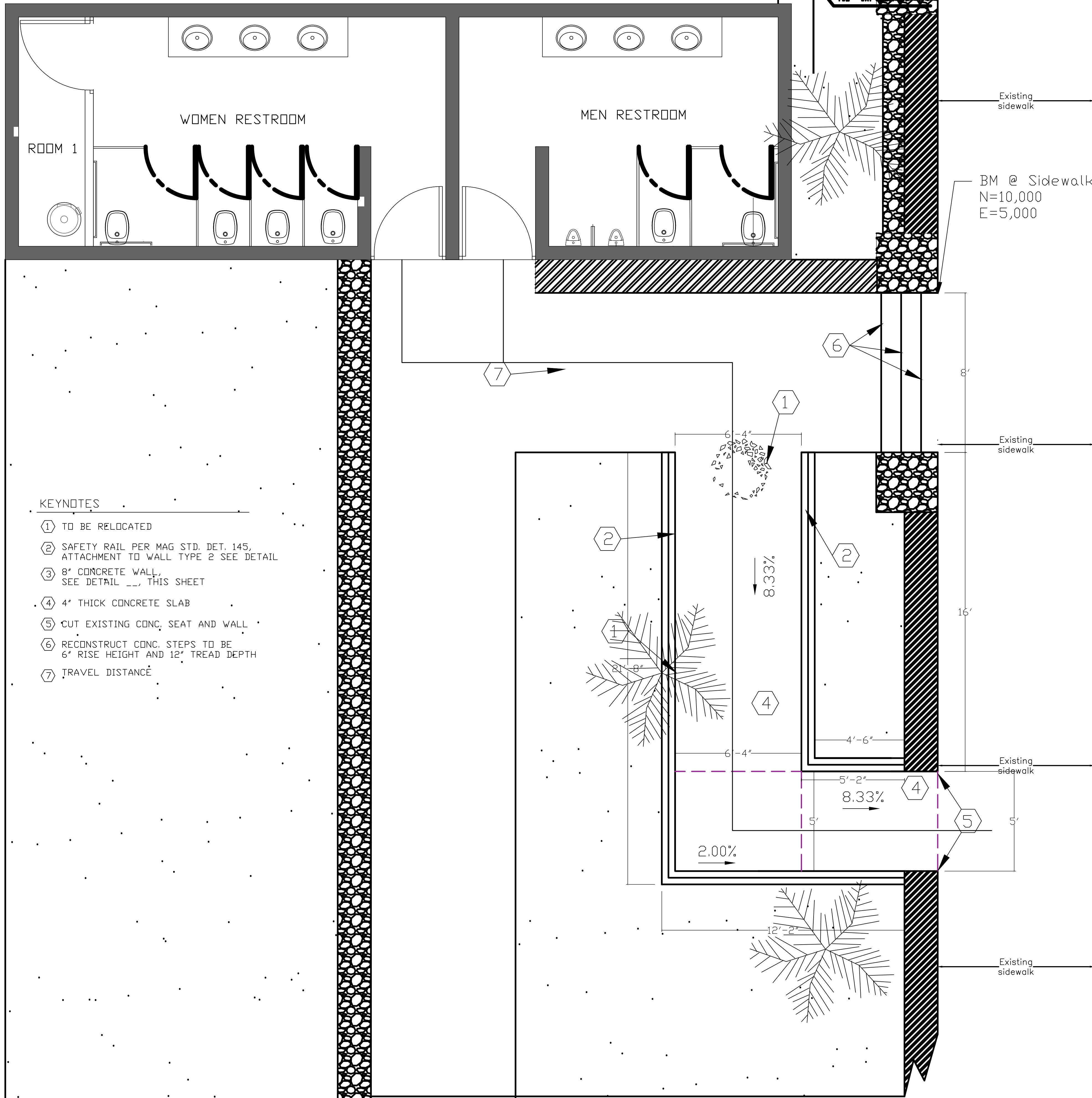

### KEYNOTES

- ① TO BE RELOCATED
- ② SAFETY RAIL PER MAG STD. DET. 145, ATTACHMENT TO WALL TYPE 2 SEE DETAIL
- ③ 8" CONCRETE WALL, SEE DETAIL \_\_, THIS SHEET
- ④ 4" THICK CONCRETE SLAB
- ⑤ CUT EXISTING CONC. SEAT AND WALL
- ⑥ RECONSTRUCT CONC. STEPS TO BE 6" RISE HEIGHT AND 12" TREAD DEPTH
- ⑦ TRAVEL DISTANCE

APPROVED



Hector Tapia, AICP  
Community Development Director

*Hector Tapia*

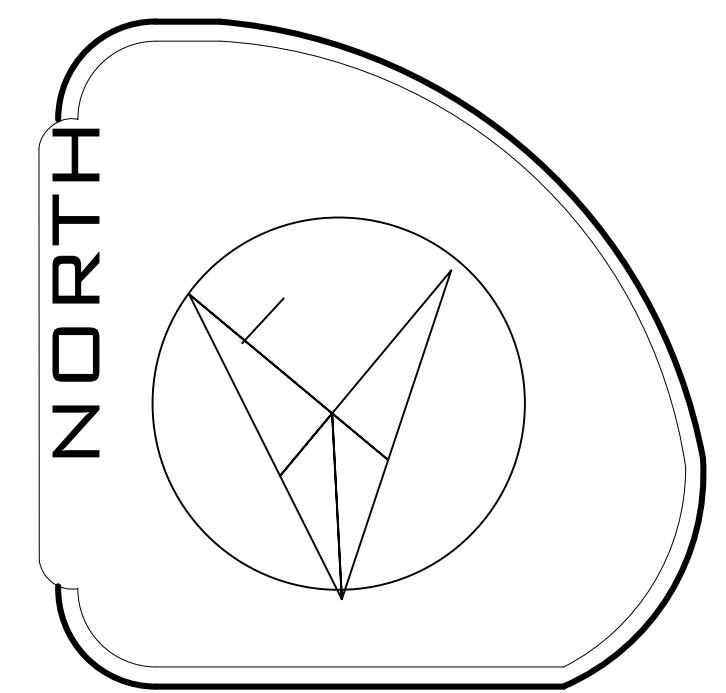

### SPECIFICATIONS

### INFO

DEPARTMENT  
**PLANNING AND ZONING**  
COMMUNITY DEVELOPMENT  
JUAN GUERRA  
JOSEPH MIRANDA

DATE:  
09/11/2024  
DIRECTOR  
HECTOR TAPIA

### PROJECT

NAME  
NOGALES DOWNTOWN  
ADDRESS  
159 N. MORLEY AVE  
NOGALES, AZ, USA.  
PLAN  
RAMP PLAN

SCALE  
1"=10'

CODE  
PLAN  
A- 07

